

Putzmeister

Stationary concrete pump

BSA 2109 H D

BSA 2109 H E

Output up to 95 m³/h
Delivery pressure up to 152 bar

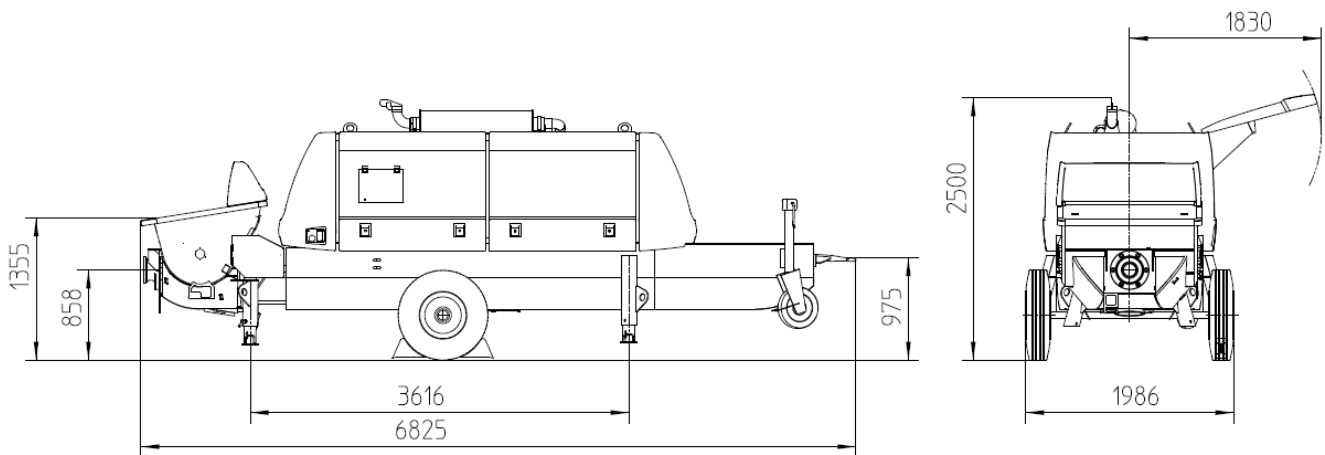

Note: Standard version BSA 2109 H D. Dimensions and weights depend on equipment.

Performance diagram

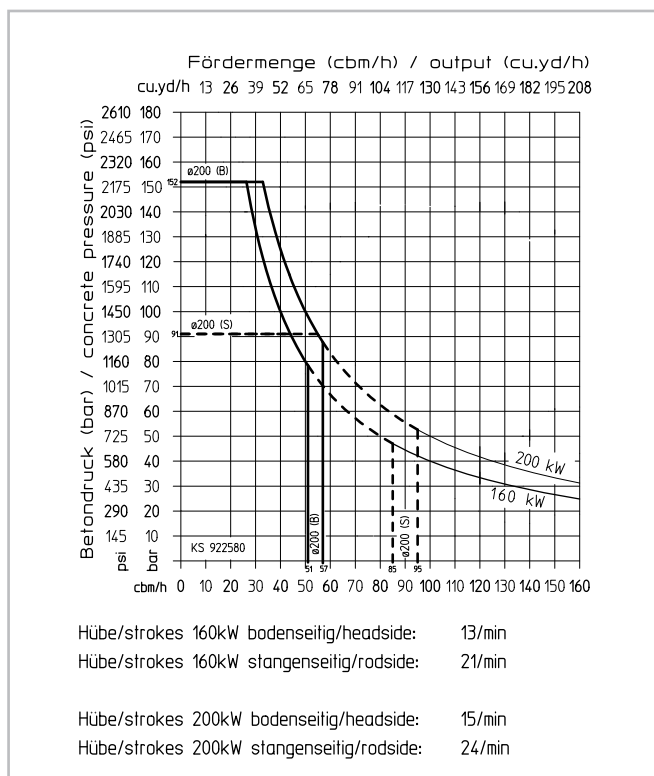

Technical data

Model		BSA 2109 H D	BSA 2109 H E
Material number		102176.000	102266.000
Output	m ³ /h	95 / 57 *	85 / 51 *
Delivery pressure	bar	91 / 152 *	
Delivery cylinder	Ø mm	200	
Delivery cyl. stroke	mm	2100	
Strokes / minute		24 / 15 *	21 / 13 *
Engine / motor power	kW	200	160
Hopper		RS 905 H	
Capacity	l	approx. 600	
Filling height	m	approx. 1.3	
Transfer tube		S 2015 D	
Line connection	mm	ZX 125	
Pressure connection	"	6	
Control system		EPS FFH	
Weight	kg	6300	6600

* Values for hydraulic fluid being fed to piston-side
All data maximum theoretical

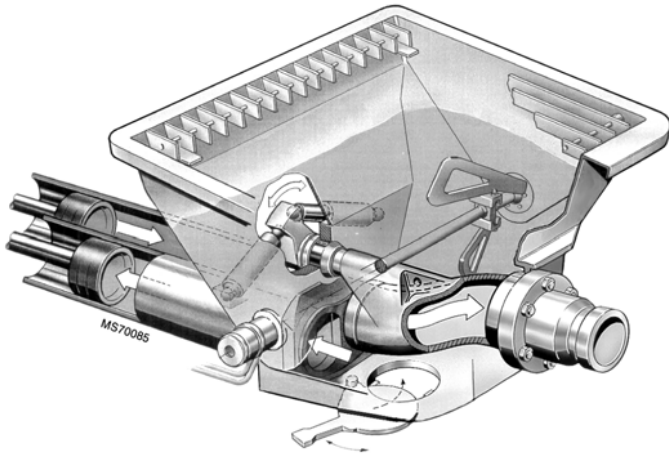

Hopper with transfer tube

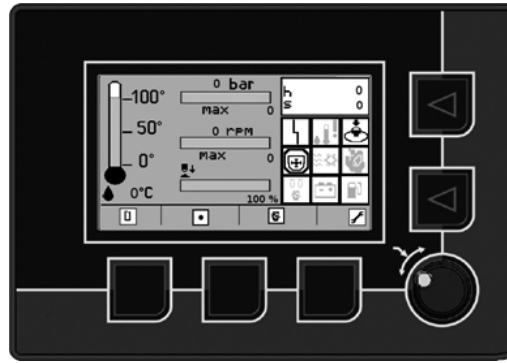

EGD - Ergonic Graphic Display

Serial equipment

Agitator safety switch off
Cable remote control 10 m
Central lubrication on hopper with hand lever press
Cleaning accessories
Coloring: Cover chrome yellow / black Pump, frame and trailer light-grey Roof and splash guard black-grey
Concrete hopper with agitator
Coupling ring (DIN)
Drive diesel, Deutz 200 kW (BSA 2109 H D)
Drive electric 160 kW (BSA 2109 H E)
Flushing water pump 50 l/min 20 bar
Gate valve connection
Grill 70 mm
Hard metal wear parts
Operating manuals (1 x paper, 1 x CD-ROM) spare part list
Outriggers 4 x mech.
Splash guard
Support wheel
Tool set incl. standard equipment
Trailer F8, travelling in site

Ergonic equipment

Concrete output adjust
Concrete pressure adjust
Electronic error management
Ergonic Graphic Display (EGD)
Pump flow meter
Speed drawdown automatically on pump stop (BSA 2109 H D)

See quotation for exact serial delivery scope.
Comprehensive range of options available on request.