

Pecco SK 280-20

TOWER CRANE

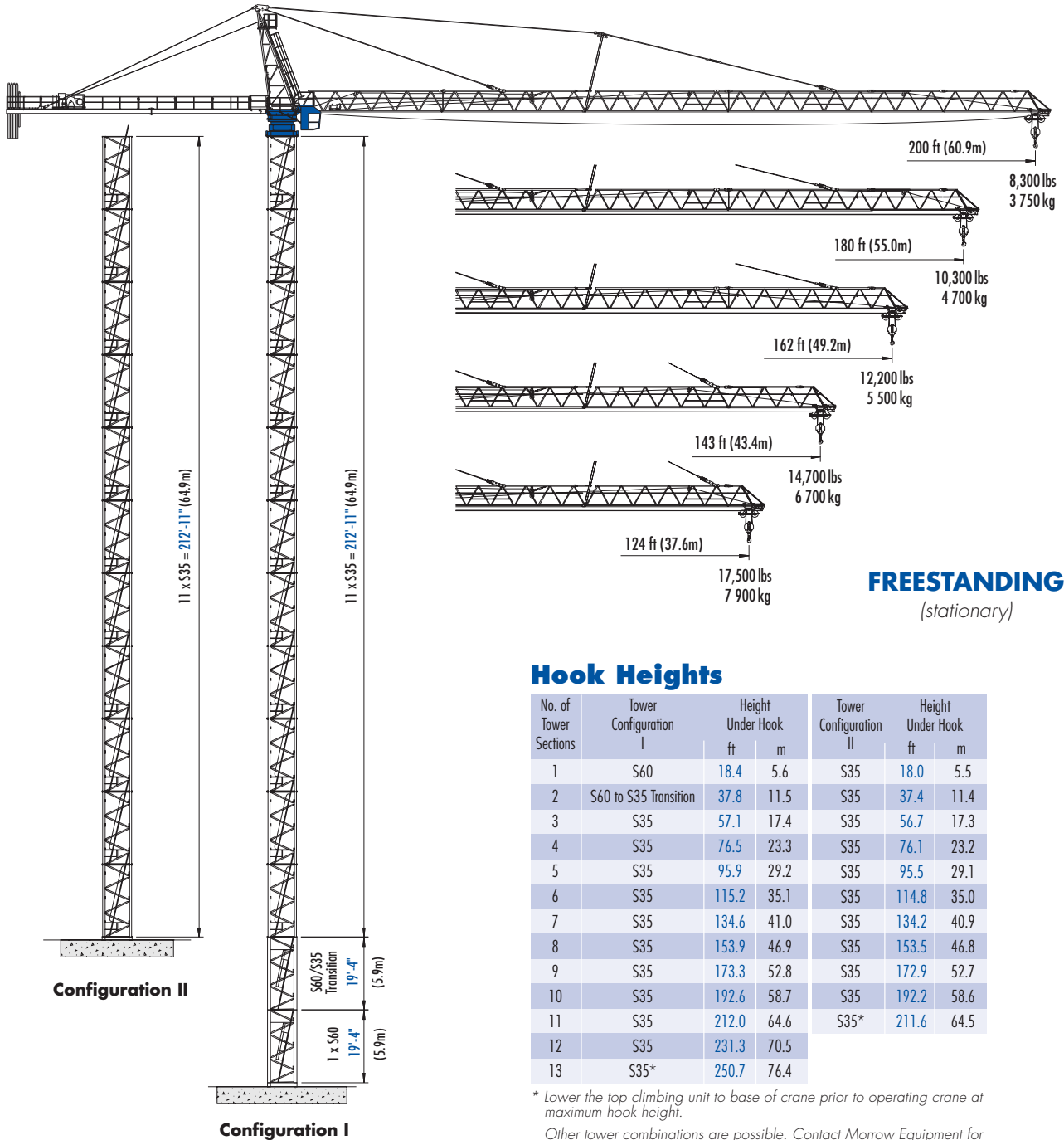

Hook Heights

No. of Tower Sections	Tower Configuration I	Height Under Hook		Tower Configuration II	Height Under Hook	
		ft	m		ft	m
1	S60	18.4	5.6	S35	18.0	5.5
2	S60 to S35 Transition	37.8	11.5	S35	37.4	11.4
3	S35	57.1	17.4	S35	56.7	17.3
4	S35	76.5	23.3	S35	76.1	23.2
5	S35	95.9	29.2	S35	95.5	29.1
6	S35	115.2	35.1	S35	114.8	35.0
7	S35	134.6	41.0	S35	134.2	40.9
8	S35	153.9	46.9	S35	153.5	46.8
9	S35	173.3	52.8	S35	172.9	52.7
10	S35	192.6	58.7	S35	192.2	58.6
11	S35	212.0	64.6	S35*	211.6	64.5
12	S35	231.3	70.5			
13	S35*	250.7	76.4			

* Lower the top climbing unit to base of crane prior to operating crane at maximum hook height.

Other tower combinations are possible. Contact Morrow Equipment for additional information.

Configurations

Pecco SK 280-20

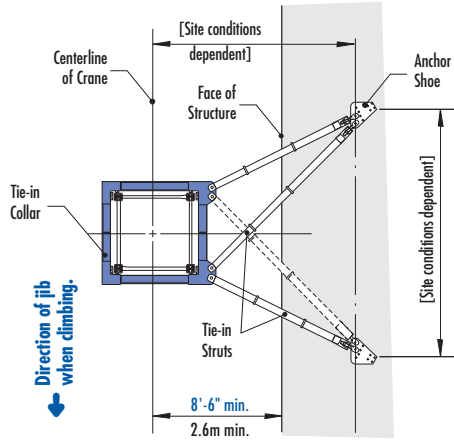

TIE-IN ASSEMBLY
(Plan View)

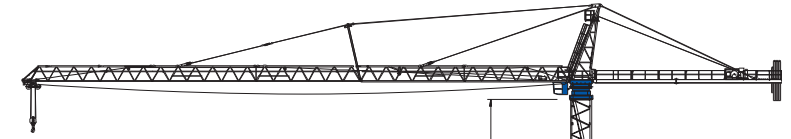

NOTE! If hook height exceeds 330 ft (100m), the number of tower sections above the uppermost tie-in location **MUST** be reduced by 1 tower section.

* Lower the top climbing unit to the uppermost tie-in prior to operating crane at maximum hook height.

Consult Morrow for specific information regarding alternate foundation details, dimensions, tie-in locations, reaction forces and slab openings.

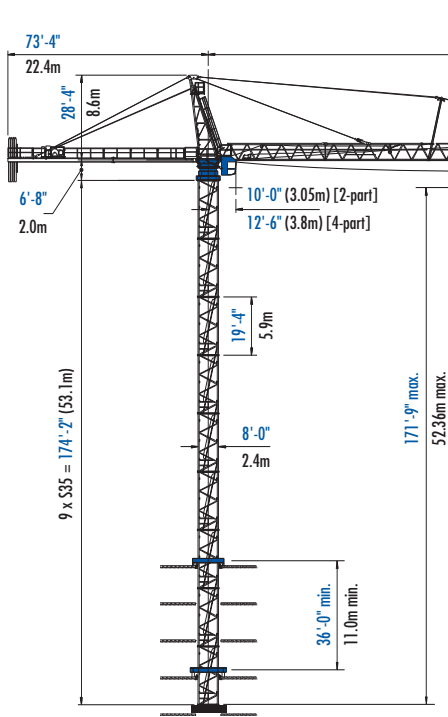

BOTTOM CLIMBING
with S35 Tower Sections
(Inside Structure)

IMPORTANT! Please consult crane's operation manual before erecting, operating and dismantling crane.

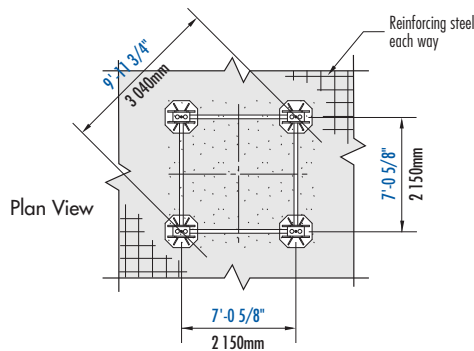
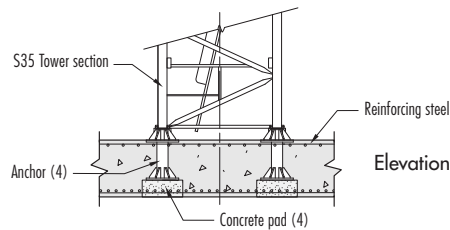

FOUNDATION DETAILS
with S35 Tower Sections
(Concrete Slab)

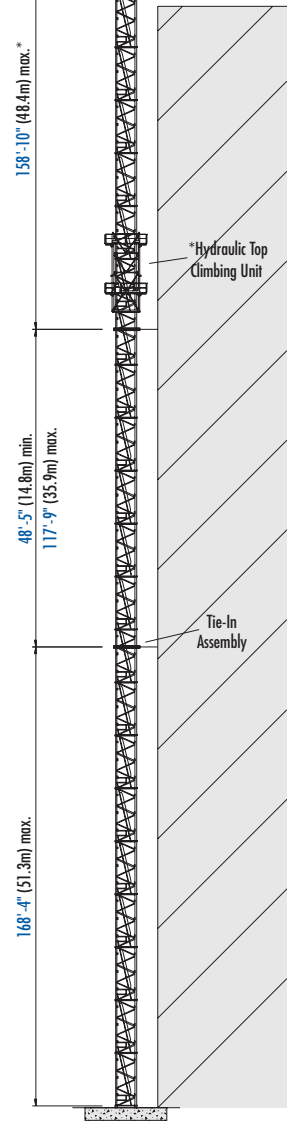

TOP CLIMBING
with S35 Tower Sections
(Tied to Structure)

Radius and Capacities

Pecco Tower Crane Model SK 280-20

2-Part Line

Hook Radius	2-Part Line Max Capacity – Radius	ft m	98 30.0	108 32.9	118 36.0	124 37.6	128 39.0	134 40.8	138 42.1	143 43.4	151 46.0	157 47.9	162 49.2	167 50.9	174 53.0	180 55.0	187 57.0	193 58.8	200 60.9	
200 ft 60.9m	22,050 lbs – 85 ft 10 000 kg – 26.0m	lbs kg	19,000 8 620	17,000 7 710	15,400 6 990	14,700 6 670	14,000 6 350	13,300 6 030	12,900 5 850	12,400 5 620	11,600 5 260	11,000 4 990	10,700 4 850	10,200 4 630	9,700 4 400	9,300 4 220	9,000 4 080	8,600 3 900	8,300 3 750	
180 ft 55.0m	22,050 lbs – 92 ft 10 000 kg – 28.0m	lbs kg	20,700 9 390	18,600 8 440	16,800 7 620	16,000 7 260	15,300 6 940	14,500 6 580	14,000 6 350	13,600 6 170	12,600 5 720	12,100 5 490	11,700 5 310	11,200 5 080	10,700 4 850	10,300 4 700				
162 ft 49.2m	22,050 lbs – 95 ft 10 000 kg – 29.0m	lbs kg	21,600 9 800	19,400 8 800	17,600 7 980	16,700 7 580	16,000 7 260	15,100 6 850	14,700 6 670	14,200 6 440	13,200 5 990	12,600 5 720	12,200 5 500							
143 ft 43.4m	22,050 lbs – 98 ft 10 000 kg – 30.0m	lbs kg	22,050 10 000	20,100 9 120	18,100 8 210	17,300 7 850	16,500 7 480	15,600 7 080	15,200 6 900	14,700 6 700										
124 ft 37.6m	22,050 lbs – 98 ft 10 000 kg – 30.0m	lbs kg	22,050 10 000	20,300 9 210	18,400 8 350	17,500 7 900														

Capacity

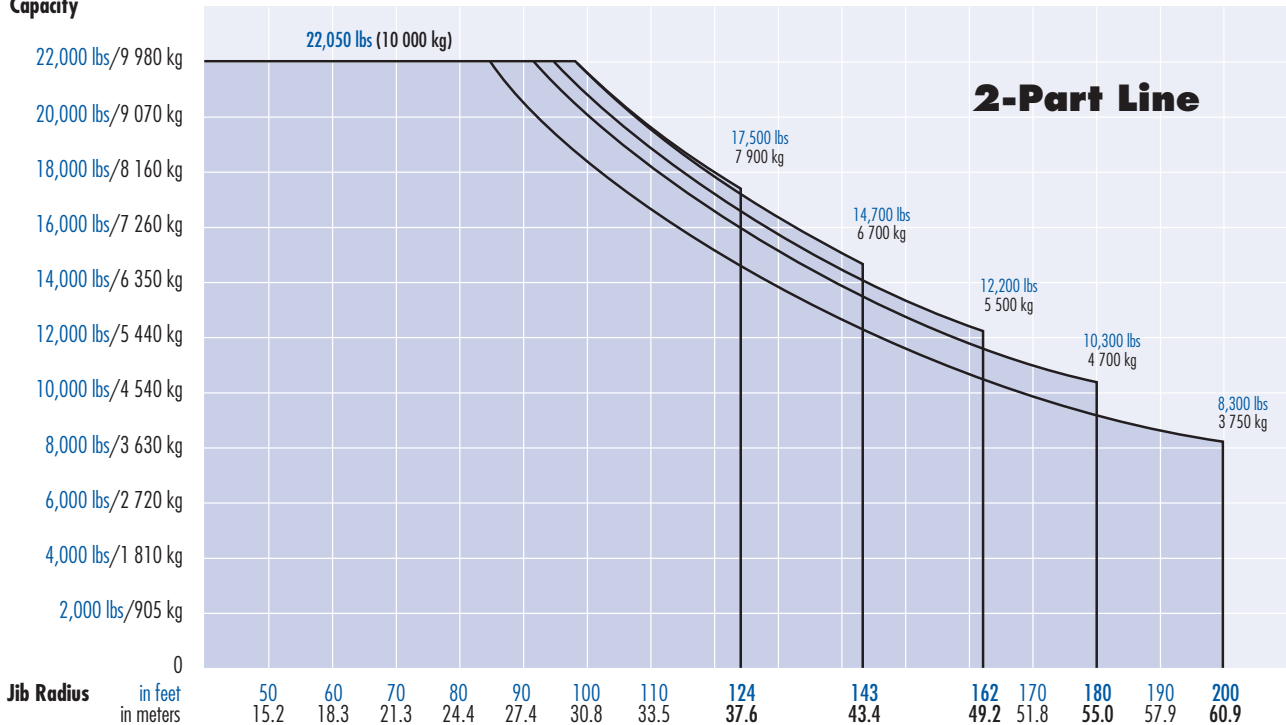

Radius and Capacities

Pecco Tower Crane Model SK 280-20

4-Part Line

Hook Radius	4-Part Line	ft	40	49	59	72	82	92	102	112	121	131	140	151	159	171	178	187	197	
	Max Capacity – Radius	m	12.2	14.9	18.0	22.0	25.0	28.0	31.1	34.1	36.9	40.0	42.7	46.0	48.5	52.1	54.3	57.0	60.0	
197 ft 60.0m	44,100 lbs – 43 ft 20 000 kg – 13.0m	lbs kg	44,100 20 000	40,000 18 150	32,200 14 610	25,200 11 430	21,600 9 800	18,700 8 480	16,500 7 480	14,600 6 620	13,210 5 990	11,800 5 350	10,740 4 870	9,700 4 400	9,080 4 120	8,200 3 720	7,670 3 480	7,100 3 220	6,600 3 000	
178 ft 54.3m	44,100 lbs – 46 ft 20 000 kg – 14.0m	lbs kg	44,100 20 000	43,400 19 690	34,900 15 830	27,500 12 470	23,500 10 660	20,500 9 300	18,100 8 210	16,000 7 260	14,510 6 580	13,000 5 900	11,840 5 370	10,800 4 900	10,080 4 570	9,100 4 130	8,600 3 900			
159 ft 48.5m	44,100 lbs – 49 ft 20 000 kg – 14.9m	lbs kg	44,100 20 000	44,100 20 000	36,300 16 470	28,600 12 970	24,500 11 110	21,300 9 660	18,800 8 530	16,800 7 620	15,210 6 900	13,600 6 170	12,440 5 640	11,300 5 130	10,500 4 800					
140 ft 42.7m	44,100 lbs – 51 ft 20 000 kg – 15.5m	lbs kg	44,100 20 000	44,100 20 000	38,000 17 240	29,900 13 560	25,700 11 660	22,400 10 160	19,700 8 940	17,600 7 980	15,930 7 230	14,300 6 490	13,200 6 000							
121 ft 36.9m	44,100 lbs – 52 ft 20 000 kg – 15.8m	lbs kg	44,100 20 000	44,100 20 000	38,200 17 330	30,100 13 650	25,800 11 700	22,500 10 210	19,900 9 030	17,700 8 030	16,000 7 300									

Capacity

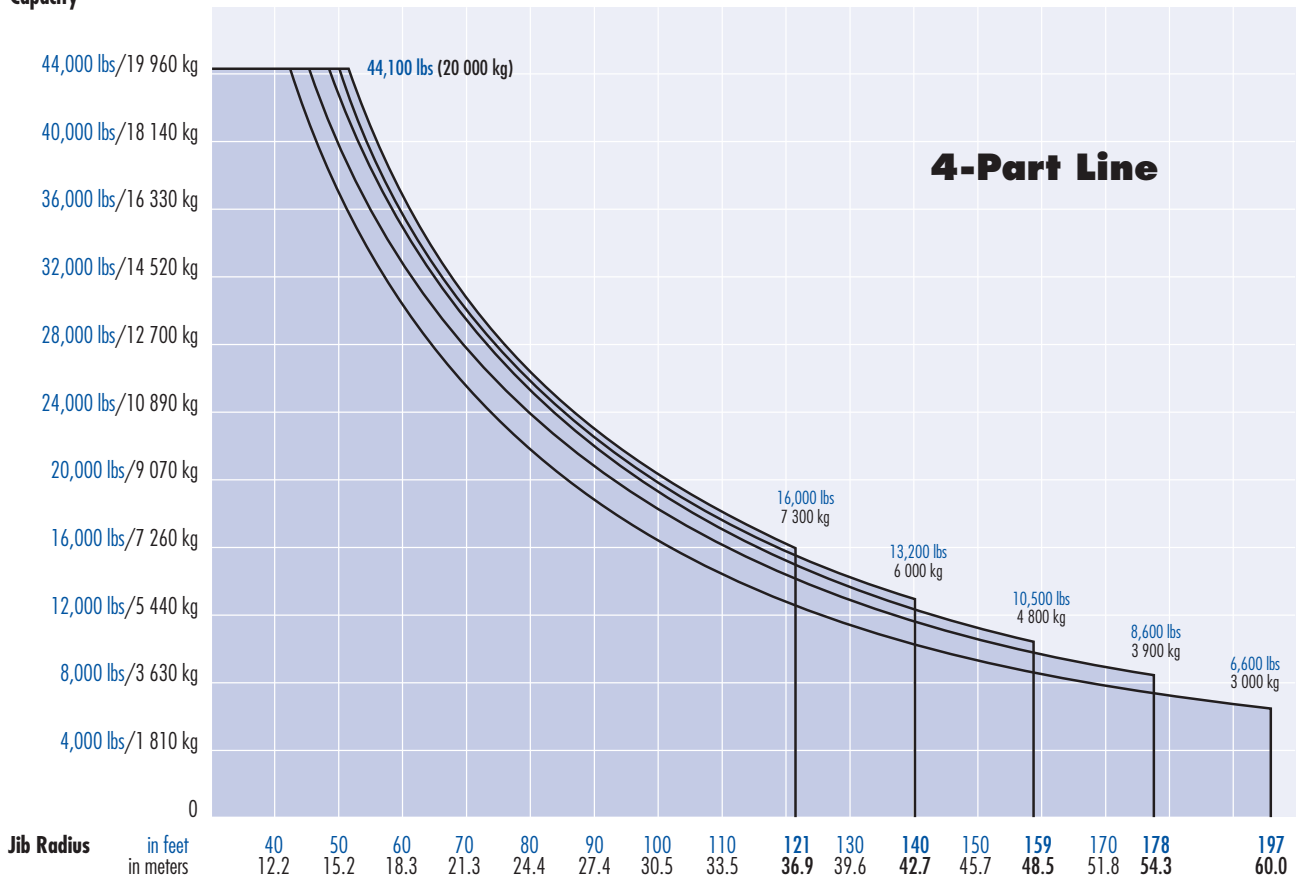

SPECIFICATIONS

Pecco Tower Crane Model SK 280-20

Hoist Speed and Capacity

Hoist Unit	2-Part Line				
105 hp (78 kW) AC hoist unit 4-speed gearbox Remote-controlled gear shifting Eddy current brake	Gear	Capacity	Hoist Speed	Capacity	Hoist Speed
	1	up to 22,050 lbs	@ 110 fpm	up to 10 000 kg	@ 34 m/min
	2	up to 15,600 lbs	@ 178 fpm	up to 7 100 kg	@ 54 m/min
	3	up to 9,250 lbs	@ 282 fpm	up to 4 200 kg	@ 86 m/min
	4	up to 5,500 lbs	@ 440 fpm	up to 2 500 kg	@ 134 m/min
	4-Part Line				
	1	up to 44,100 lbs	@ 55 fpm	up to 20 000 kg	@ 17 m/min
	2	up to 31,200 lbs	@ 89 fpm	up to 14 200 kg	@ 27 m/min
3	up to 18,500 lbs	@ 141 fpm	up to 8 400 kg	@ 43 m/min	
4	up to 11,000 lbs	@ 220 fpm	up to 5 000 kg	@ 67 m/min	

2P140
4P70

Hoist Unit	2-Part Line				
165 hp (122 kW) AC hoist unit 4-speed gearbox Remote-controlled gear shifting Eddy current brake	Gear	Capacity	Hoist Speed	Capacity	Hoist Speed
	1	up to 22,050 lbs	@ 160 fpm	up to 10 000 kg	@ 48 m/min
	2	up to 17,600 lbs	@ 250 fpm	up to 8 000 kg	@ 76 m/min
	3	up to 10,600 lbs	@ 400 fpm	up to 4 800 kg	@ 120 m/min
	4	up to 6,200 lbs	@ 630 fpm	up to 2 800 kg	@ 192 m/min
	4-Part Line				
	1	up to 44,100 lbs	@ 80 fpm	up to 20 000 kg	@ 24 m/min
	2	up to 35,200 lbs	@ 125 fpm	up to 16 000 kg	@ 38 m/min
3	up to 21,200 lbs	@ 200 fpm	up to 9 600 kg	@ 60 m/min	
4	up to 12,400 lbs	@ 315 fpm	up to 5 600 kg	@ 96 m/min	

2P230
4P115

NOTE! Capacities and line speeds indicated will vary depending on the amount of hoist rope installed. This crane model may be equipped with a hoist unit other than that specified in the data above. To verify, check the serial number of the crane and refer to the Pecco SK 280-20 Operation Manual for additional information.

Motor Information

Drive Unit	Horsepower	Kilowatts	Speed	
Trolley	12 hp	9 kW	0 - 320 fpm	0 - 96 m/min
Swing *	2 x 12 hp	2 x 9 kW	1.0 rpm	

* **NOTE!** Jibs up to and including 143-ft (43.4m) hook reach require only one swing motor; jibs with 162-ft (49.2m) hook reach and longer require two swing motors.











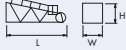

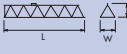

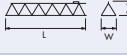









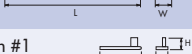

Power Requirements

480 V — 3-phase — 60 Hz — 250 Amperes (for 105 hp/78 kW AC hoist unit) or 300 Amperes (for 165 hp/122 kW AC hoist unit)

Specifications subject to change without notice. For other configurations and specifications, contact Morrow Equipment.

Component List

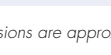
Pecco SK 280-20

Description	Dimensions L x W x H	Weight	Description	Dimensions L x W x H	Weight
Tower Top	 30'-0" x 6'-8" x 7'-3" 9.14m x 2.03m x 2.21m	6,620 lbs 3 000 kg	Jib Section ①	 38'-9" x 6'-1" x 6'-2" 11.8m x 1.85m x 1.88m	6,800 lbs 3 080 kg
Turntable (Complete) Upper & Lower Part	 9'-4" x 10'-0" x 10'-2" 2.84m x 3.03m x 3.1m	19,800 lbs 8 980 kg	Jib Section ②	 38'-9" x 6'-1" x 5'-11" 11.8m x 1.85m x 1.8m	4,400 lbs 2 000 kg
Turntable Upper Part ¹	 9'-4" x 6'-10" x 7'-0" 2.84m x 2.08m x 2.13m	10,200 lbs 4 625 kg	Jib Section ③	 38'-9" x 6'-1" x 5'-11" 11.8m x 1.85m x 1.8m	3,000 lbs 1 360 kg
Turntable Lower Part ²	 8'-8" x 10'-0" x 3'-2" 2.65m x 3.03m x 0.97m	9,600 lbs 4 355 kg	Jib Section ④	 38'-9" x 6'-1" x 5'-11" 11.8m x 1.85m x 1.8m	3,000 lbs 1 360 kg
Operator's Cab	 5'-11" x 4'-3" x 7'-1" 1.8m x 1.3m x 2.16m	900 lbs 410 kg	Jib Section ⑤	 19'-9" x 6'-1" x 5'-11" 6.02m x 1.85m x 1.8m	1,600 lbs 725 kg
Cab Access Platform	 12'-8" x 5'-7" x 2'-9" 3.85m x 1.7m x 0.85m	1,000 lbs 455 kg	Jib Section ⑥	 19'-9" x 6'-1" x 5'-11" 6.02m x 1.85m x 1.8m	1,200 lbs 545 kg
Tower Section S35	 19'-5" x 7'-10" x 8'-0" 5.92m x 2.4m x 2.44m	8,900 lbs 4 040 kg	Jib Section ⑧	 9'-11" x 6'-4" x 7'-1" 3.02m x 1.93m x 2.16m	1,000 lbs 455 kg
Transition Section S60 to S35	 19'-5" x 7'-11" x 7'-11" 5.92m x 2.41m x 2.41m	9,930 lbs 4 500 kg	Jib Assembly Part 1 ⁶ for all Jib Assemblies	①② 76'-2" x 6'-1" x 6'-2" 23.2m x 1.85m x 1.88m	16,150 lbs 7 325 kg
Tower Section S60	 19'-5" x 7'-11" x 7'-11" 5.92m x 2.41m x 2.41m	9,930 lbs 4 500 kg	Jib Assembly Part 2 ⁷ 200-ft (60.9m)	③④⑤⑥⑧ 123'-9" x 6'-4" x 7'-1" 37.7m x 1.93m x 2.16m	10,900 lbs 4 945 kg
Counterjib ³ (Complete)	 69'-3" x 9'-1" x 8'-4" 21.1m x 2.77m x 1.8m	20,220 lbs 9 170 kg	Jib Assembly Part 2 ⁷ 180-ft (55.0m)	③④⑤⑧ 104'-9" x 6'-4" x 7'-1" 31.9m x 1.93m x 2.16m	9,700 lbs 4 400 kg
Counterjib Section #1 (Inner)	 30'-8" x 6'-4" x 5'-5" 9.35m x 1.93m x 1.66m	6,000 lbs 2 720 kg	Jib Assembly Part 2 ⁷ 162-ft (49.2m)	③④⑧ 85'-9" x 6'-4" x 7'-1" 26.1m x 1.93m x 2.16m	7,300 lbs 3 310 kg
Counterjib Section #2 ⁴ (Outer)	 38'-7" x 9'-1" x 5'-11" 11.75m x 2.77m x 1.8m	14,220 lbs 6 450 kg	Jib Assembly Part 2 ⁷ 143-ft (43.4m)	③⑤⑧ 66'-8" x 6'-4" x 7'-1" 20.3m x 1.93m x 2.16m	5,900 lbs 2 675 kg
Hoist Unit ⁵ (105 hp/78 kW)	 9'-2" x 8'-11" x 4'-7" 2.79m x 2.72m x 1.4m	10,220 lbs 4 635 kg	Jib Assembly Part 2 ⁷ 124-ft (37.6m)	③⑧ 47'-8" x 6'-4" x 7'-1" 14.5m x 1.93m x 2.16m	4,300 lbs 1 950 kg
Hoist Unit ⁵ (165 hp/122 kW)	 9'-2" x 8'-11" x 4'-7" 2.9m x 2.72m x 1.4m	12,300 lbs 5 580 kg	Top Climbing Unit with Hydraulics (S35)	 29'-3" x 11'-6" x 11'-6" 8.9m x 3.5m x 3.5m	24,750 lbs 11 230 kg
Counterweight Block A	 14'-8" x 7'-5" x 5'-1" 4.47m x 0.19m x 1.55m	6,800 lbs 3 085 kg	Jib A-frame	 21'-7" x 5'-5" x 4'-8" 6.57m x 0.14m x 1.43m	800 lbs 360 kg
Counterweight Block B	 9'-5" x 5'-5" x 5'-1" 2.87m x 0.14m x 1.55m	3,200 lbs 1 450 kg	Tie-in Collar S35	 10'-0" x 1'-0" x 11'-6" 3.05m x 0.3 x 3.5m	4,000 lbs 1 815 kg
2-Part Trolley (Outer)	 5'-7" x 7'-1" x 4'-2" 1.7m x 2.16m x 1.28m	950 lbs 430 kg	Hook Block	 2'-5" x 1'-1" x 5'-7" 0.74m x 0.33m x 1.69m	1,000 lbs 454 kg

NOTE! Weights and dimensions are approximate. Scale components before lifting.

¹ Turntable Upper Part includes swing motors and slewing ring. Does not include slewing ring support and support frame.

² Turntable Lower Part includes slewing ring support and support frame. Does not include Upper Part, slewing ring and swing motors.

³ Includes Counterjib Sections #1 and #2, 105 hp (78 kW) AC hoist unit with frame, electrical panels and handrails. Does not include wire rope. If alternate 165 hp (122 kW) hoist unit is installed, Counterjib (Complete) increases by 2,100 lbs (950 kg).

⁴ Counterjib Section #2 includes 105 hp (78 kW) AC hoist unit with frame, electrical panels and handrails. Does not include wire rope. If alternate 165 hp (122 kW) hoist unit is installed, Counterjib Section #2 increases by 2,100 lbs (950 kg).

⁵ Includes frame and electrical panels. Does not include wire rope.

⁶ Jib Assembly Part 1 includes jib sections, pendant cables, jib A-frame, trolley drive unit, trolley wire rope, 2-part trolley (outer) and hook block. If 4-part application is used, weight increases by 1,950 lbs (885 kg) for additional trolley (inner) and hook block.

⁷ Jib Assembly Part 2 includes jib sections and pendant cables.